

FLOWCINE

GRAVITY ONE

MOUNTING AND OPERATIONS
MANUAL V01

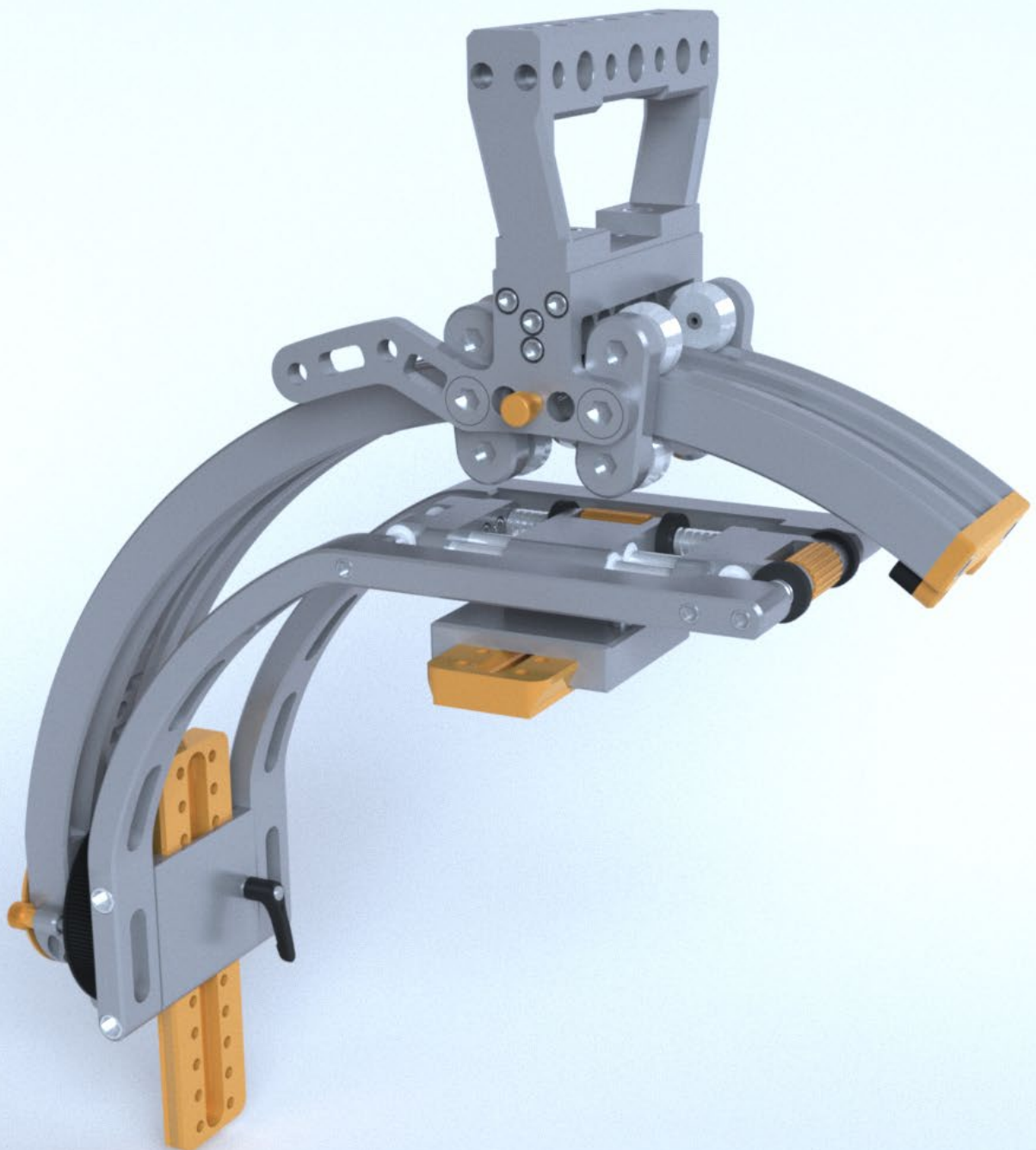

GRAVITY ONE — THE SMALL LIGHTWEIGHT EXTERNAL 2 AXIS GIMBAL RIG

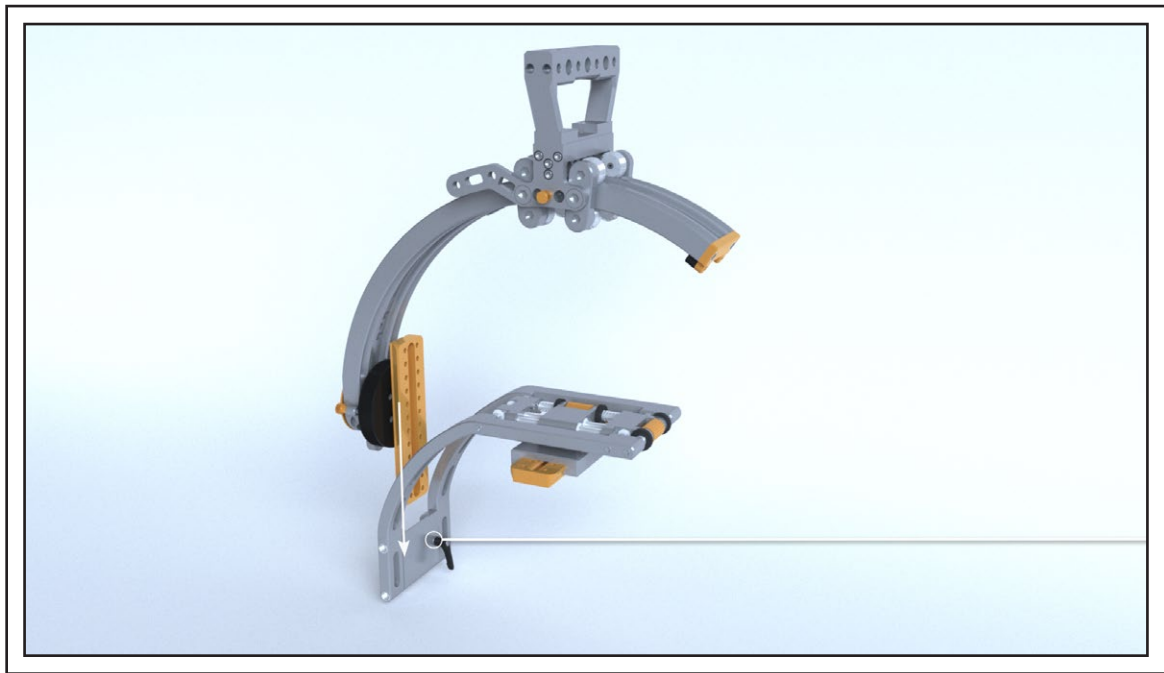

01. The first time you balance the system the easiest way is to take it step-by-step. First remove the inner bow from the G-1 by releasing the tilt knob. The tilt dovetail has a very tight fit, and you might need to push the knob inwards against the dovetail until you hear a "click" sound. This is purely a safety mechanism, so the innerbow accidentally doesn't slide off. Once separated we begin by checking where the COG is on the camera.

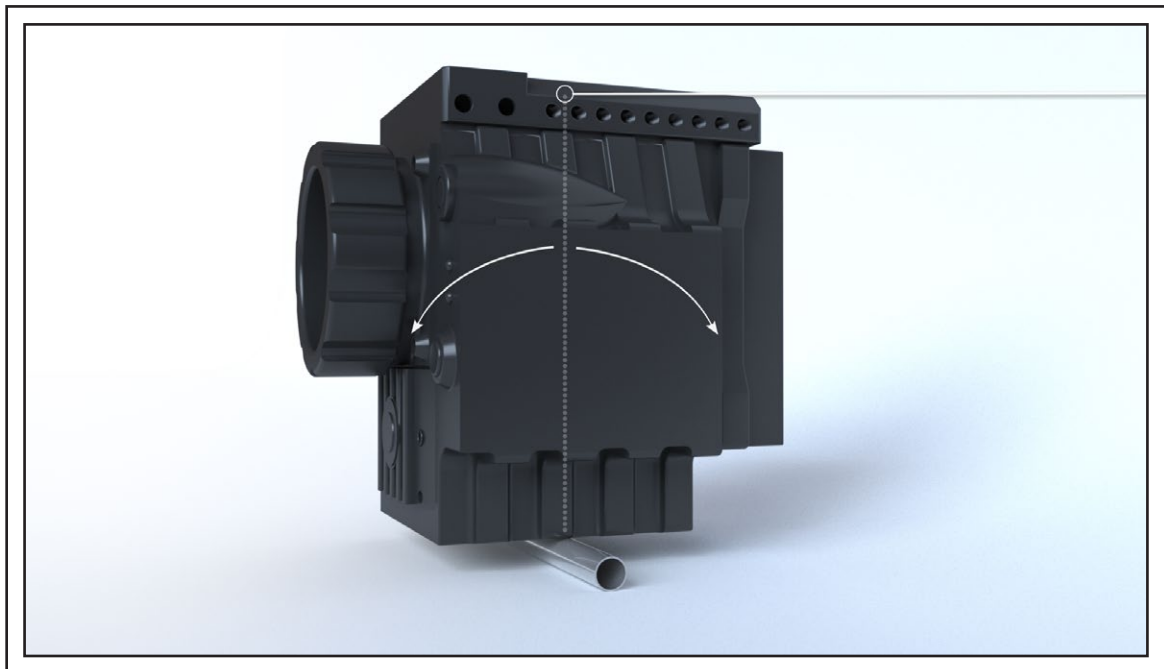

02. The image shows just a camera body, but in your case you need to have all the accessories already assembled on the camera. So mount all accessories before proceeding further! Most important is to set up the monitor on the left side of the camera in a good viewing position. Working with a EVF won't work well with the Gravity One due to how its constructed.

Also be aware so that no accessories are colliding with the outer bow, since your camera set up, will need clearance in order to tilt correctly without damaging any equipment. All cables, and loose parts also need to be tighten so they don't move around thus leading to a unbalanced system. When using noga arms, make sure these are properly tightened, so the equipment you placed on them doesn't start drifting over time.

The first step is to see roughly were the balance is on the camera from the front to back. This is easiest done by placing a rod or a pen under the camera, and see where the point is where it doesn't tip forward/backward. Mark this on top of your camera.

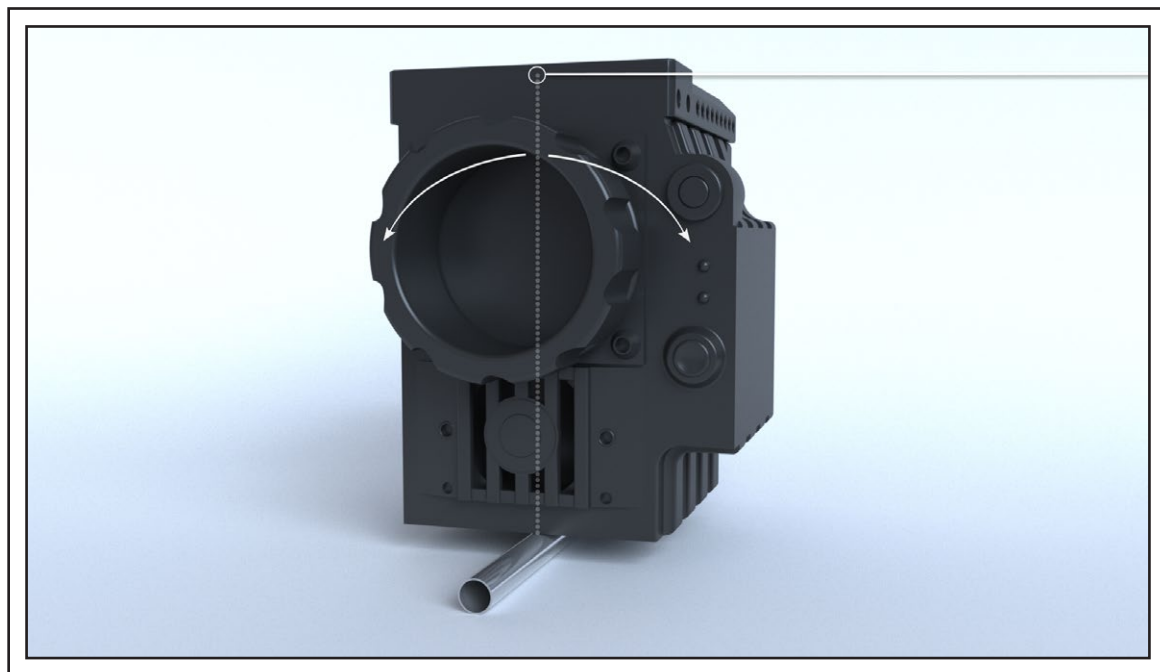

The next step is to find where the balance is from side to side. Repeat the procedure above.

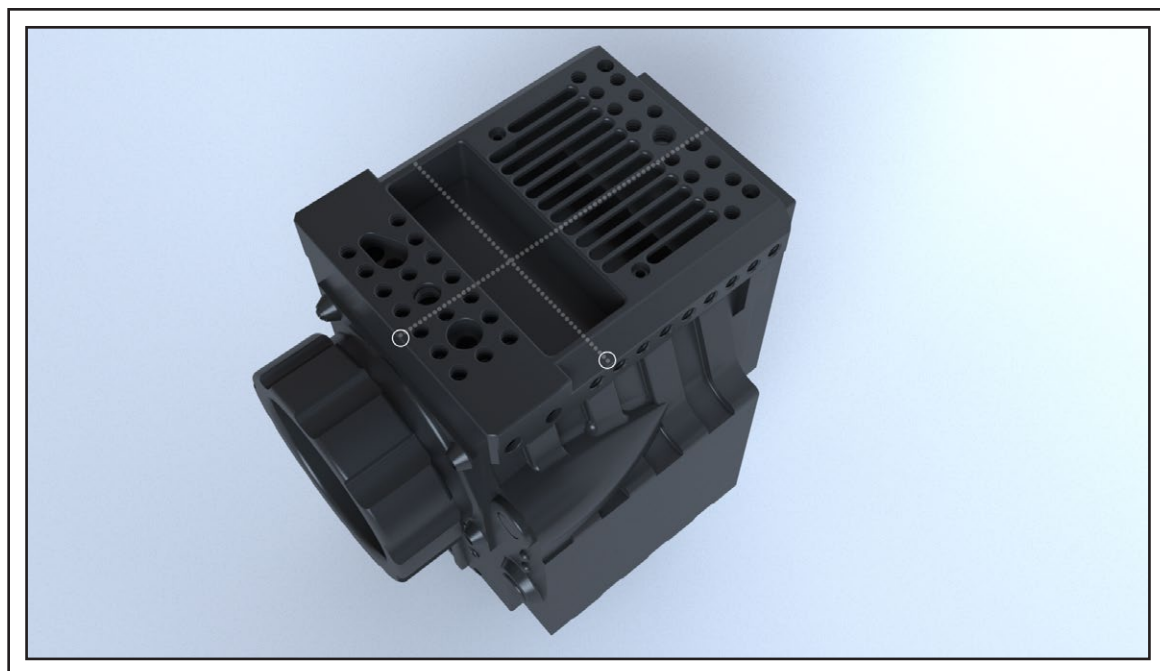

Please note that you either need a top plate, a cage, our Arri adaption plate or the smart grip in order to be able to attach the G-1 camera dovetail on top of your camera setup.

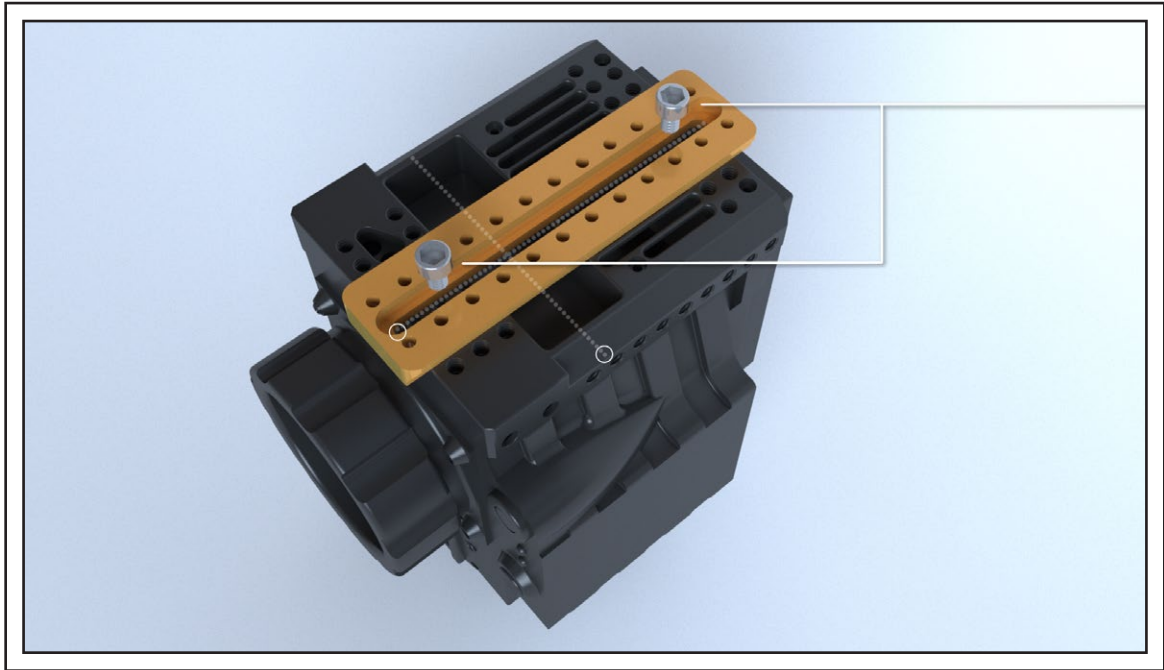

03. Now when we know where our COG is on the total camera set up, including monitor offset on the left side, batteries, matte box, lens motors, etc, we fasten the G-1 camera dovetail with either two 1/4-20 screws, or two M5 screws with washers, depending on what your top plate looks like, on the COG side to side line mark.

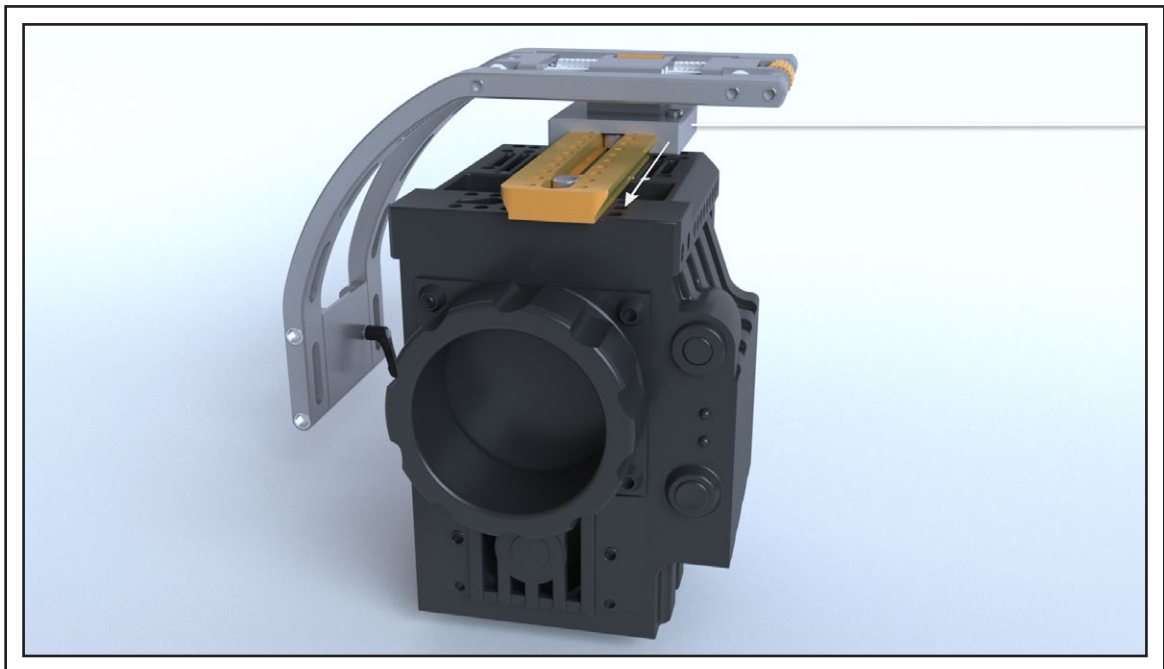

04. Slide on the inner bow on top of the dovetail, until its roughly at the same place where your front/back balance is on the camera set up.

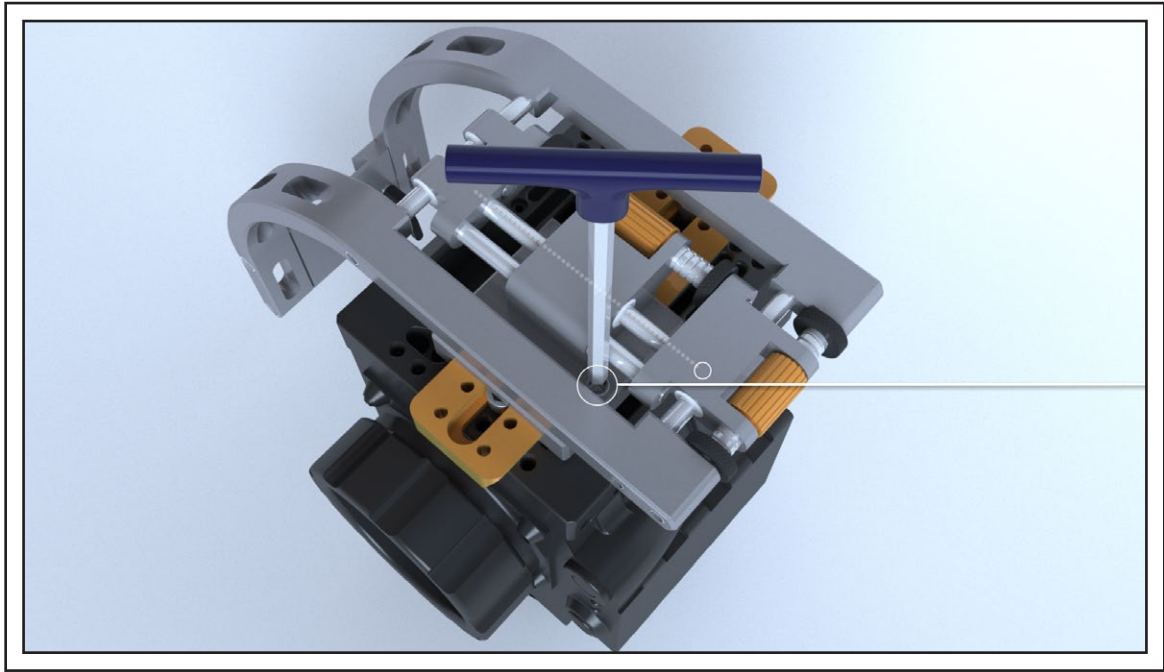

05. Use a 4mm Allen tool for M5 screw, to tighten the bolt on the trim stage, securing the inner bow on the dovetail. When releasing this lock, you might need to press down the Allen tool until you hear a small click, just like on the tilt stage to release the lock.

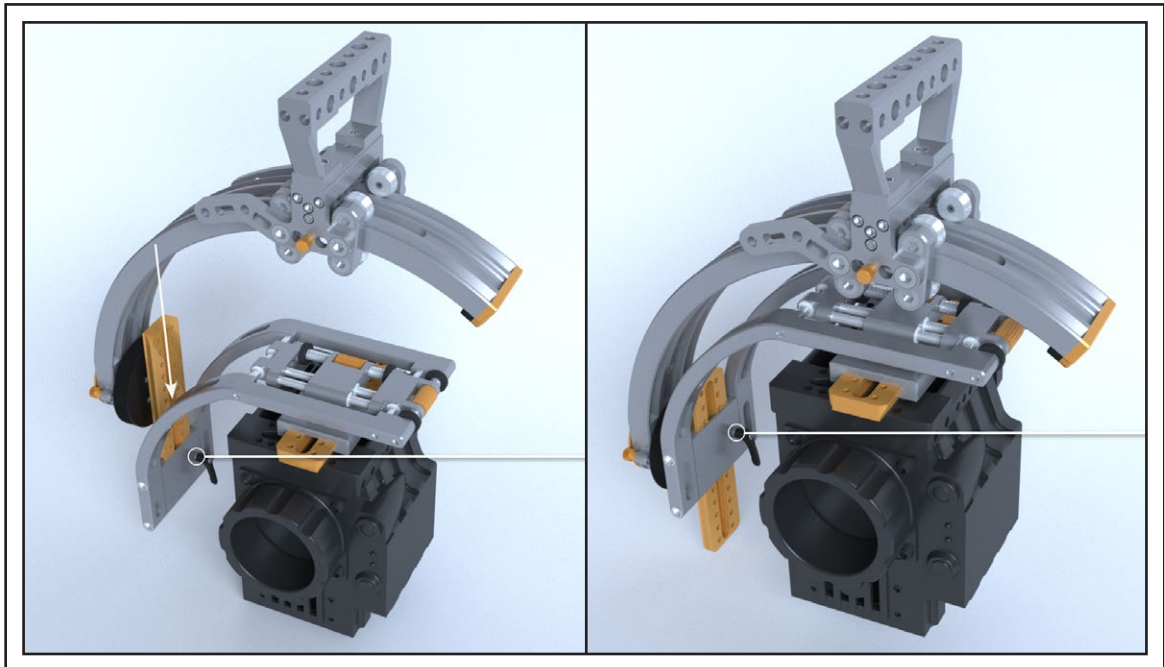

06. If you lift the inner bow now with your fingers, you should feel that the camera is well centered front to back around the middle of the inner bow. If everything is ok, you can now attach the outer bow on the tilt stage, and lock the dovetail with the flowcine knob. In the beginning, you can place the inner bow quite low on the tilt dovetail, so the system become bottom heavy. We will correct this at a later stage.

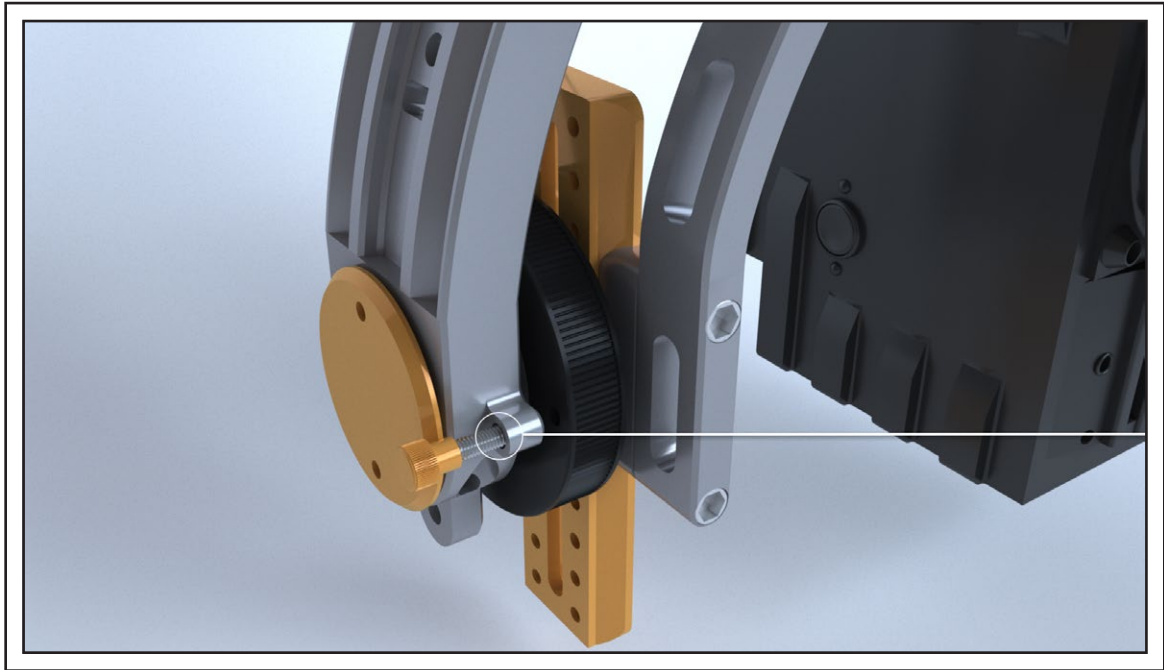

- 07.** Release the tilt lock, by gently unscrew the knob enough for the inner bow to rotate freely without scratching the pulley.

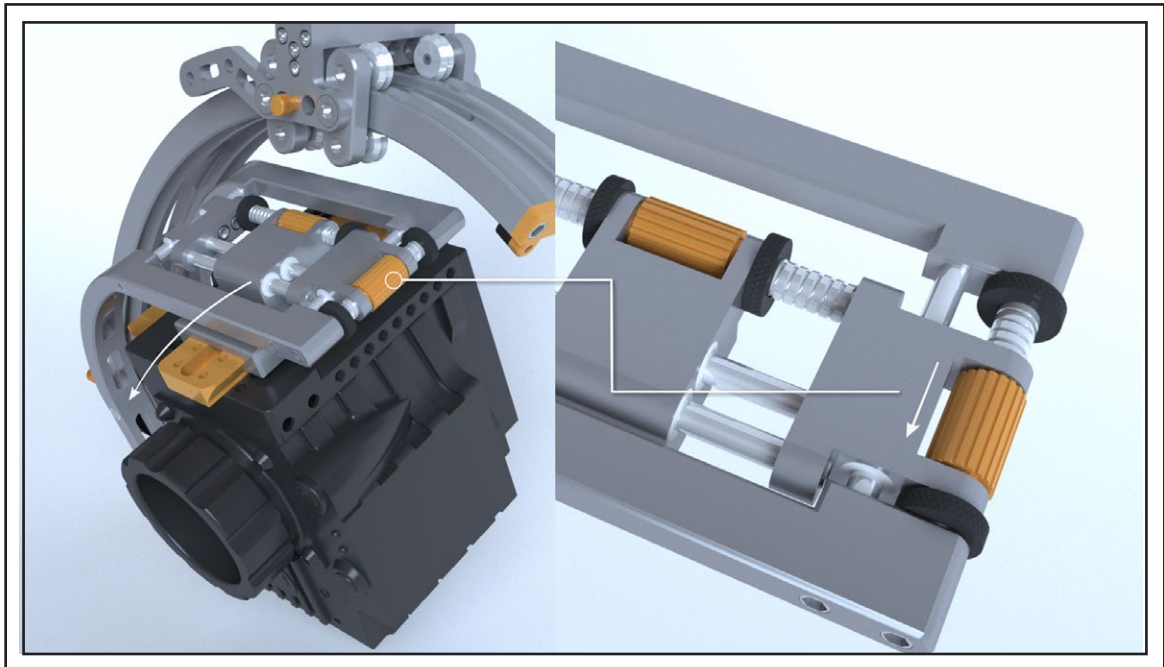

- 08.** Gently lift the camera, and fine tune the balance by adjusting the trim stage by rotating the trim wheel. If the camera tilts forward, then screw the wheel according to the picture.

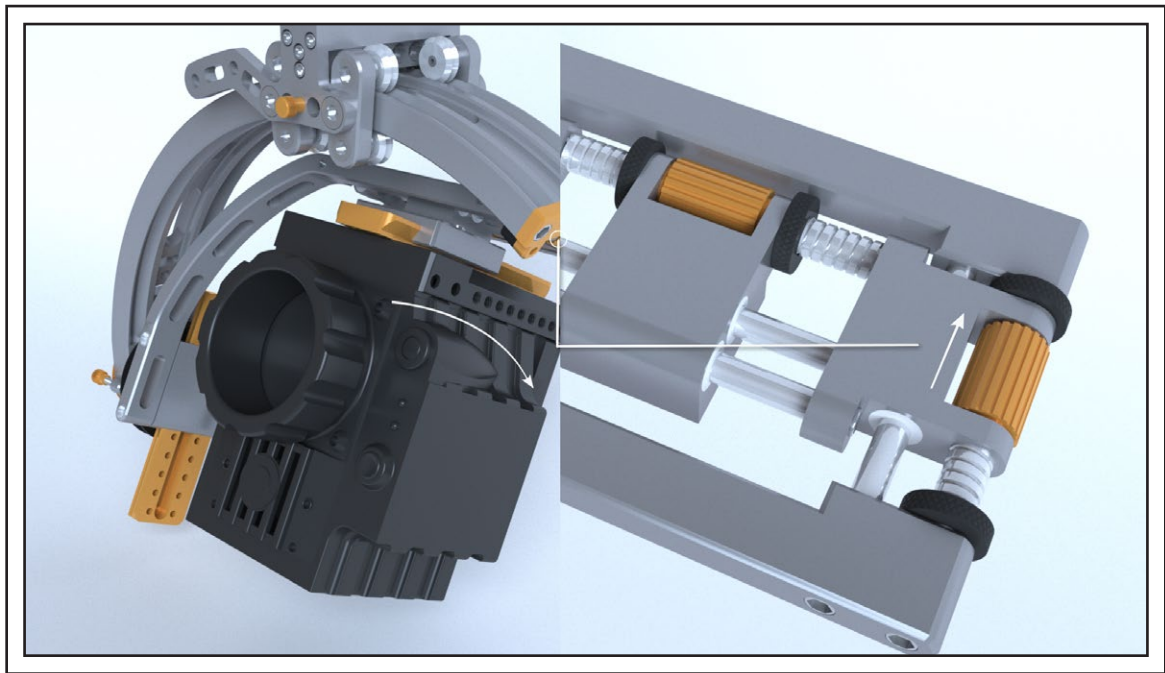

If the camera tilt backwards, screw the wheel in the other direction.

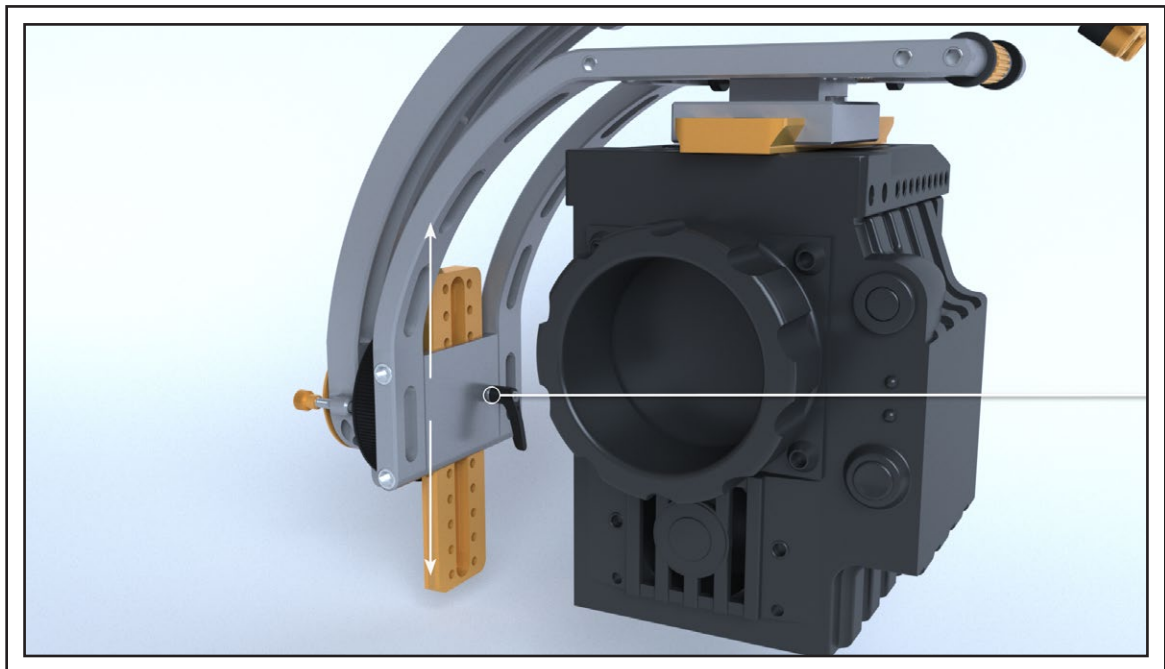

If the camera seems impossible to balance, its because the innerbow is mounted to high on the tilt dovetail. Please lower this by adjusting the innerbow up/down, until you have perfect balance and the camera neither wants to tilt forward or backward, if you manually tilt it forward, and let it go. Once you found the balance, adjust the innerbow a little lower so it gentle settle itself in the centre after letting it go making it somewhat bottom heavy.

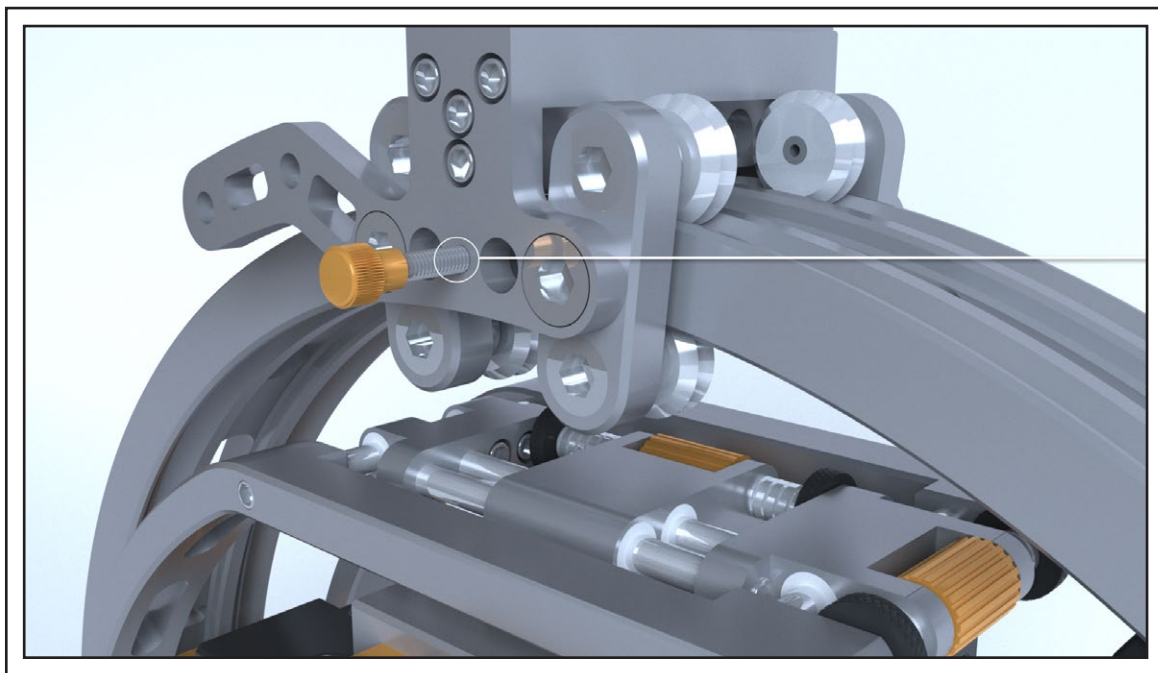

09. Now its time to correct the balance around the roll. Release the roll lock by unscrewing it enough, so it doesn't scratch the outer bow.

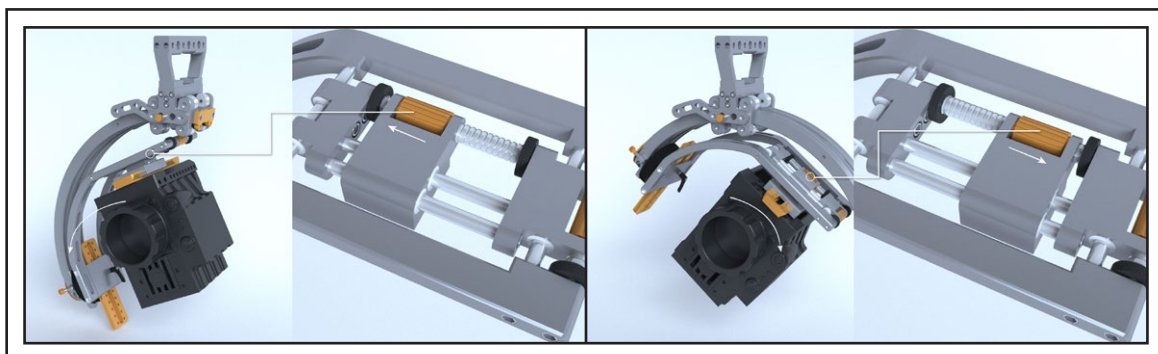

10. If you lift the G-1 in the handle camera probably will roll to the left and right. Use the other trim wheel to correct this, by rotating the wheel. Correct this according to the pictures.

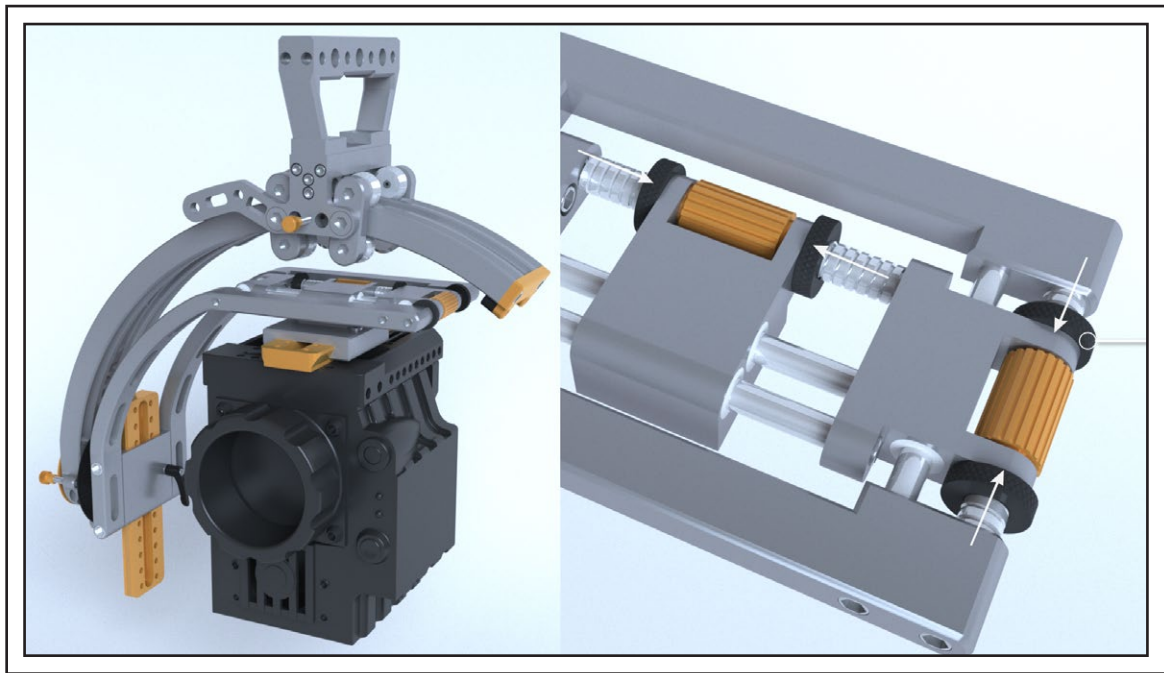

11. Once you're happy with the balance, please use the trim stage locks, but screwing them again the trim wheels firmly. If you adjust anything on the camera like changing lens etc, you will need to trim the balance again. Usually this is done fast with just the trim screws on the trim stage, but for larger change of balance you might need to unscrew the bolt on the trim lock and reposition the inner bow on the camera dovetail.

Now you're ready to shoot! Expect a slight learning curve the first couple of hours. In half a day you will be quite an expert!

CAUTION!

01. When transporting the G-1, please let the tilt and roll locks to be free, so they don't get bent during transportation.

02. The tilt and roll locks are meant as help to have the G-1 standing up when you put the system on a tripod or the floor, and to make the balancing process easier. They should NOT be locked when carrying the camera around in the handle, since this creates a lot of torque, thus easily damaging the locks.

03. Never UNDO the four M4 screws that are placed in a triangular shape (seen at the top of image 09.) and the two flathead M8 screws that hold the arms that carry the roller bearings.